

KD10

Pneumatic & Electric Globe Control Valve PN16 - PN40

The **KD10** is a two-way, single-seat top guided globe valve construction, designed to offer a comprehensive range of control valves for fluids such as steam, water, oil, and general industrial fluids.

Thanks to its high rangeability, modular design, and outstanding flexibility, the **KD10** series can meet a wide variety of industrial process control requirements, from the simplest to the most complex.

The **KD10** range offers multiple configurations, including reduced bores, noise-reducing and anti-cavitation trims, to perfectly adapt to any control and regulation need, even under the most demanding conditions.



14/68/EU (PED)

Notified Body 2942



14/34/EU (ATEX)

Notified Body 0948



Safety Integrity Level

IEC EN 61508



Fugitive emissions

ISO 15848-1

- ◆ From DN15 to DN300 rating PN16/40
- ◆ Modular design
- ◆ Top Guided construction to ensure plug stability
- ◆ CEI EN 60534-6-1 Clamp and Yoke Std.
- ◆ Self-adjusting dspring loaded ouble packing
- ◆ Shutoff capabilities : Class IV (std.) , V, VI

OPTIONS

Reduced area trim to provide wide capabilities for all sizes

Hardened trims to handle high pressure drop applications

Balanced trims to handle high pressure drop & shutoff

“Quick-Change” seat ring

Cage plug design

Bellows seal to meet zero emissions (ZEB20)

Bonnet for low temperature and for high temperature

Full stainless steel actuator construction

BW / SW / RTJ connections & special on request

Heating jacket

REFERENCE STANDARDS

Quality system management certification	ISO 9001
Design std.	EN12516-2
Flange connection	EN 1092-1
Socket-Welding Ends	EN 12760
Buttwelding Ends	EN 12627
Pressure Rating	PN16 / PN40
Face to face dimension	EN 558-1
Seat tightness Class	IEC 60534-4
Positioner mounting	CEI EN 60534-6-1
2014/68/EU (PED) Certification	Modulo B + C2
Mechanical resistance calculation method	UNI EN 12516-2
Hydrostatic pressure test	EN 12266-1
Pressure / Temperature relationship	EN 1092.1
2014/34/EU (ATEX) Conformity	II 2 G Ex h IIC T6...T1 Gb II 2 D Ex h IIIC T6...T1 Db
Non-electrical equipment for explosive atmospheres Basic method and requirements	EN ISO 80079-36
Safety Integrity Level (SIL)	IEC EN 61508
Safety Integrity Level (SIL) Approval	SIL 3
Fugitive emissions Certification	ISO 15848-1
NACE	MR0175

STD VALVE BODY CHARACTERISTICS

Style	Top entry, single seated, globe valve
Sizes	from DN15 to DN300
Pressure rating	PN16 / PN40
Design std.	EN12516-2
Flange connection	EN 1092-1- Raised Face - Phonographic Groove 125-250 AARH
Face to face dimensions	EN 558-1

STD BODY & TRIM MATERIALS COMBINATION

VALVE BODY (1)	BONNET (9)	TRIM (2 and 3)	TIE ROAD	NUTS	BODY GASKET (11)
Carbon steel A216 WCC	ASTM A350 LF2 (*)	ASTM A182 F316	A193 B7	A194 H2	Graphite + Stainless steel
Stainless steel A351 CF8M	ASTM A182 F316 (*)	ASTM A182 F316	A193 B8M	A194 8M	Graphite + Stainless steel

(*) For DN250 and DN300 valve sizes, same as the valve body material

MATERIALS AVAILABLE ON REQUEST

Carbon steel	A352 LC2; A352 LC3; A352 LCC;A352 LCB
Alloy Carbon Steel	A217 WC6; A217 WC9
Austenitic Stainless Steel	A351 CF3; A351 CF8; A351 CF10;A351 CF3M; A351 CF8M;
Ferritic Austenitic Stainless Steel (DUPLEX / SUPERDUPLEX)	A995 CD3MWCuN; A995 A6;A351 CK3MCuN; A351 CE8MC; A351 CD3MN; A351 CD4MCuN
Nickel Alloy Stainless Steel	A494 M35-1 (MONEL); A494 M35-2 (MONEL); A494 N-12MV (HASTELLOY B); A494 CW-12MW (HASTELLOY C)
STUDS & NUTS	Compatible with the body material

CONSTRUCTION EXAMPLES

1. Valve Body
2. Seat ring
3. Plug
6. "Top Guide" stem
9. Bonnet
10. Stuffing box
11. Body gasket

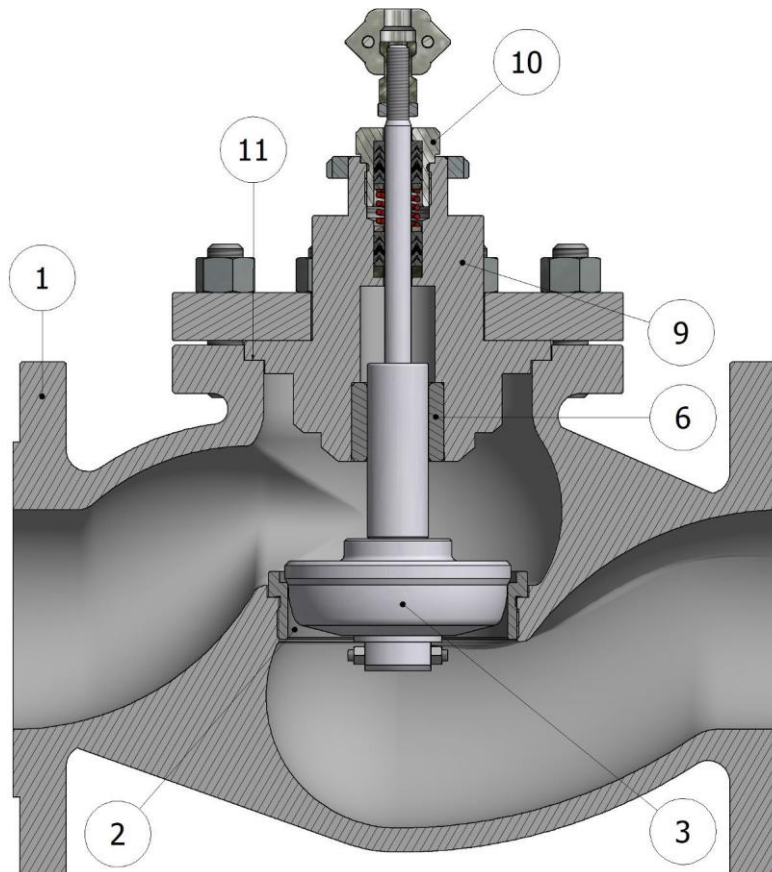

CONSTRUCTION EXAMPLES

1. Valve body
2. "Quick Change" seat ring
3. Plug
6. "Top Guide" stem
9. Bonnet
10. Stuffing box
11. Body gasket
13. Seat retainer
14. Seat gasket

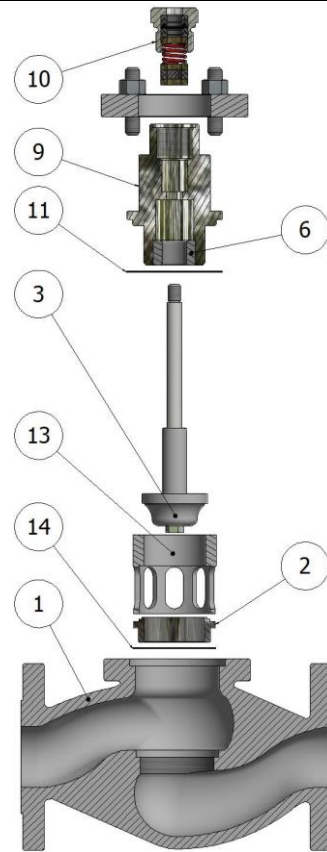

NB - Unlike the standard seat, the "Quick-Change" seat (2) is not screwed in, but is secured by component (13), allowing quick replacement in the field without the use of special tools.

**QUICK CHANGE SEAT CONTROL VALVE
WITH CONTOURED PLUG**

1. Valve Body
2. QUICK-CHANGE seat
3. Balanced plug
5. 1st stage low dB Cage
6. "Top Guide" stem
7. Balancing sleeve
8. Balancing piston
9. Bonnet
10. Stuffing box
11. Body gasket
13. Seat Retaining Cage with Control
14. Seat gasket

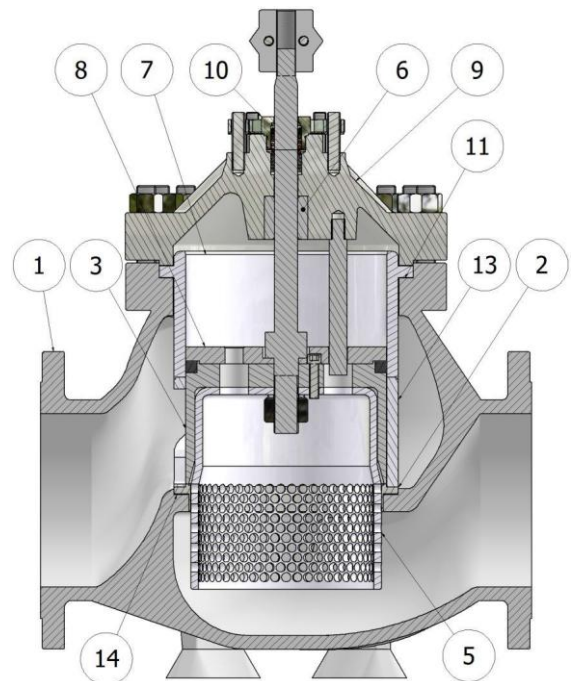

**QUICK CHANGE SEAT CONTROL VALVE
WITH BALANCED PLUG**

CONSTRUCTION EXAMPLES

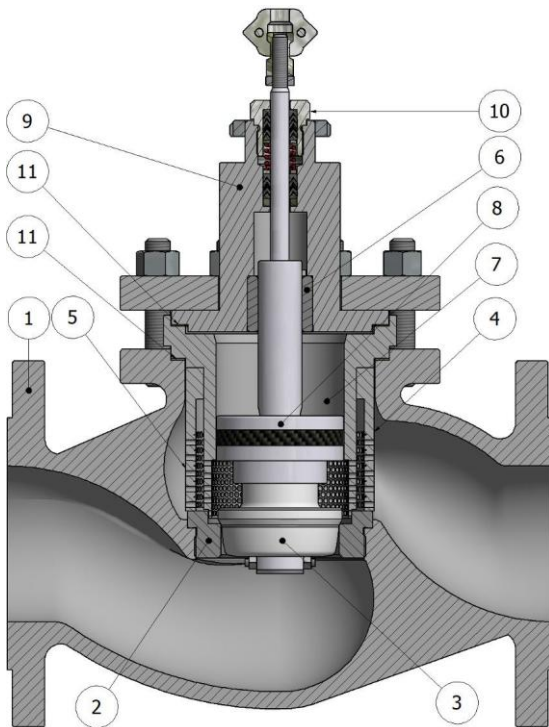

**BALANCED TRIM VALVE
WITH DOUBLE CAGE NOISE
REDUCTION**

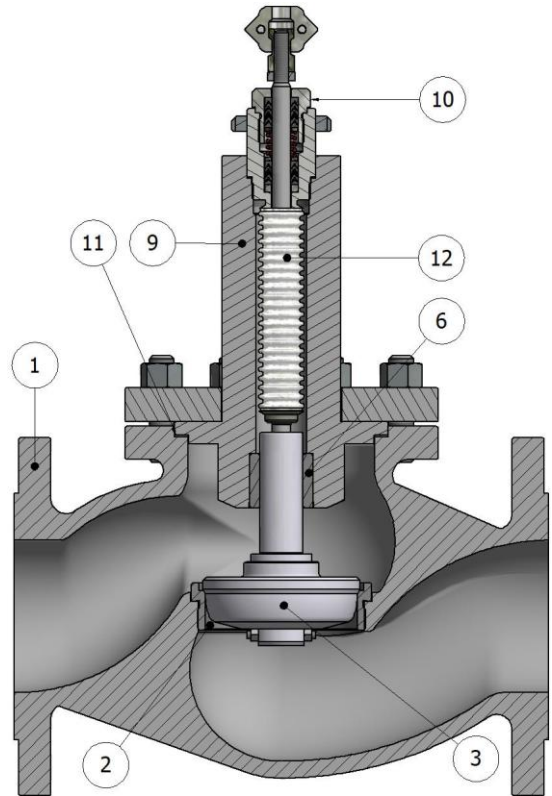

VALVE WITH BELLOWS

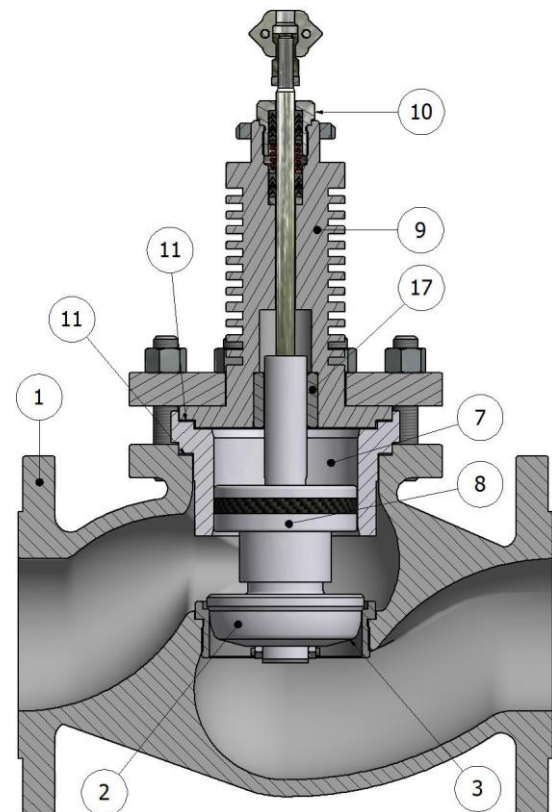

**BALANCED TRIM VALVE WITH
FINNED BONNET**

1. Valve body
2. Seat ring
3. Plug
4. 1st stage low dB Cage
5. 2nd stage low dB Cage
6. Top-guide stem
7. Balancing sleeve
8. Balancing piston
9. Bonnet
10. Stuffing box
11. Body Gasket
12. ZEB20 Bellows

VALVE STANDARD PROTECTIVE COATINGS

FLUID TEMPERATURE	VALVE BODY	BONNET	
		DN15÷DN200	From Da DN250
< 250°C	<ul style="list-style-type: none"> • Sandblasting of the component • Electrostatic thermosetting silicone powder coating RAL 9005 	Electrolytic galvanizing Fe/Zn 8 c1A UNI ISO 4520	Same as the valve body
250°C to < 600°C	<ul style="list-style-type: none"> • Heat resistant siliconic primer • Finish with siliconic enamel RAL 9006 		

PROTECTIVE COATING ON REQUEST

Customer specification colors

Painting for sea environment

Painting in according to ISO 12944



Painting in according to NORSOK M-501

NACE - FROSIO painting



Painting with colors upon request

BONNET

The bonnets are made from forged or cast material equivalent to that of the valve body

STANDARD	FINNED	EXTENDED/CRYOGENIC
<p>The standard bonnet, most commonly used, is suitable for working temperatures up to</p> <p>14°F ÷ 428°F (-10°C ÷ 220°C)</p> 	<p>Designed to dissipate heat and protect the stem packing from high process temperatures, it is used above 428°F (220°C).</p> <p>14°F ÷ 1112°F (-10°C ÷ 600°C)</p> 	<p>In the extended bonnet, a small amount of cryogenic fluid is trapped inside, creating a temperature gradient near the stem packing to protect it. It is used for temperatures below 14°F (-10°C), and its length varies depending on the minimum working temperature.</p> <p>-320°F ÷ 428°F (-196°C ÷ 220°C)</p> 

PACKING TYPE - VALVES FROM DN15 TO DN100

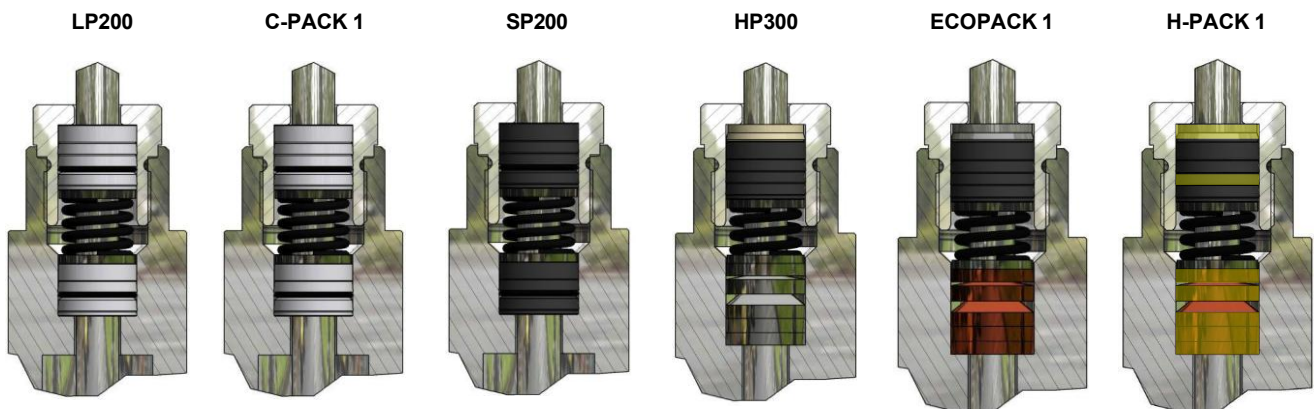

	COMPOSITION	CERTIFICATIONS
LP200	Double energized Chevron packing in virgin PTFE + V-Ring in FKM	///
C-PACK 1	Self-adjusting	ISO 15848-1 
SP200	Double energized Chevron packing in PTFE/Graphite + V-Ring in FKM Self-adjusting	///
HP300	1 energized Chevron packing in Graphite/Stainless Steel + 1 energized Chevron packing in PTFE/Graphite * Leap-seal energized	///
ECOPACK 1		ISO 15848-1 
H-PACK 1	Self-adjusting	



PACKING / BONNET TEMPERATURE CORRELATION

	LP200	C-PACK 1	SP200	HP300	ECOPACK 1	H-PACK 1
CRYOGENIC BONNET (-320 ÷ 428°F / -196 ÷ 220°C)	-320 ÷ 356°F -196 ÷ 180°C	-320 ÷ 356°F -196°C ÷ 180°C	///	///	-320 ÷ 428°F -196 ÷ 220°C	///
EXTENDED BONNET (-130 ÷ 428°F / -90 ÷ 220°C)	-130 ÷ 356°F -90 ÷ 180°C	-130 ÷ 356°F -90 ÷ 180°C	-130 ÷ 428°F -90 ÷ 220°C	///	-130 ÷ 428°F -90 ÷ 220°C	///
STANDARD BONNET (14 ÷ 428°F / -10 ÷ 220°C)	14 ÷ 356°F -10 ÷ 180°C	14 ÷ 356°F -10 ÷ 180°C	14 ÷ 428°F -10 ÷ 220°C	///	14 ÷ 428°F -10 ÷ 220°C	14 ÷ 428°F -10 ÷ 220°C
FINNED BONNET (14 ÷ 788°F / -10 ÷ 420°C)	///	///	14 ÷ 500°F -10 ÷ 260°C	14 ÷ 788°F -10 ÷ 420°C	14 ÷ 752°F -10 ÷ 400°C	14 ÷ 788°F -10 ÷ 420°C
FINNED BONNET (14 ÷ 968°F / -10 ÷ 520°C)	///	///	///	14 ÷ 968°F -10 ÷ 520°C	///	14 ÷ 968°F -10 ÷ 520°C
FINNED BONNET (14 ÷ 1112°F / -10 ÷ 600°C)	///	///	///	14 ÷ 1112F -10 ÷ 600°C	///	14 ÷ 1112F -10 ÷ 600°C

PACKING TYPE - (a) VALVES FROM DN125 TO DN250 - (b) VALVES DN300

	COMPOSITION	CERTIFICATIONS
LP400 (a)	1 energized Chevron packing in virgin PTFE + Leaklock FKM ring + energized Lip-seal rings	///
C-PACK 2 (a)	Self-adjusting	ISO 15848-1 
SP400 (a)	1 energized Chevron packing in PTFE/Graphite + Leaklock FKM ring + energized Lip-seal rings Self-adjusting	///
HP600 (a) HP900 (b)	1 energized Chevron packing in Graphite/ Stainless Steel + 1 energized Chevron packing in PTFE/Graphite + energized Leap-seal	///
ECOPACK 2 (a)	Self-adjusting	ISO 15848-1 
H-PACK 2 (a)		

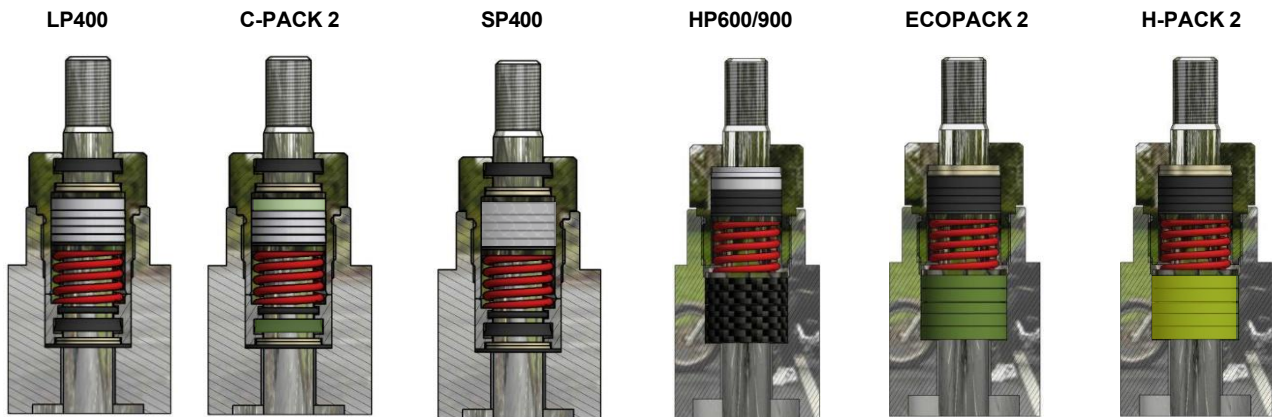

PACKING / BONNET TEMPERATURE CORRELATION

	LP400	C-PACK 2	SP400	HP600	ECOPACK 2	H-PACK 2
CRYOGENIC BONNET (-320 ÷ 428°F / -196 ÷ 220°C)	-320 ÷ 356°F -196 ÷ 180°C	-320 ÷ 356°F -196°C ÷ 180°C	///	///	-320 ÷ 428°F -196 ÷ 220°C	///
EXTENDED BONNET (-130 ÷ 428°F / -90 ÷ 220°C)	-130 ÷ 356°F -90 ÷ 180°C	-130 ÷ 356°F -90 ÷ 180°C	-130 ÷ 428°F -90 ÷ 220°C	///	-130 ÷ 428°F -90 ÷ 220°C	///
STANDARD BONNET (14 ÷ 428°F / -10 ÷ 220°C)	14 ÷ 356°F -10 ÷ 180°C	14 ÷ 356°F -10 ÷ 180°C	14 ÷ 428°F -10 ÷ 220°C	///	14 ÷ 428°F -10 ÷ 220°C	14 ÷ 428°F -10 ÷ 220°C
FINNED BONNET (14 ÷ 788°F / -10 ÷ 420°C)	///	///	14 ÷ 500°F -10 ÷ 260°C	14 ÷ 788°F -10 ÷ 420°C	14 ÷ 752°F -10 ÷ 400°C	14 ÷ 788°F -10 ÷ 420°C
FINNED BONNET (14 ÷ 968°F / -10 ÷ 520°C)	///	///	///	14 ÷ 968°F -10 ÷ 520°C	///	14 ÷ 968°F -10 ÷ 520°C
FINNED BONNET (14 ÷ 1112°F / -10 ÷ 600°C)	///	///	///	14 ÷ 1112°F -10 ÷ 600°C	///	14 ÷ 1112°F -10 ÷ 600°C

ZEB20 BELLOWS FOR DANGEROUS FLUIDS

The ZEB20 is used in industrial applications where leakage of process fluid from the stem packing poses a risk to the environment and, in the most critical cases, to personnel safety.

The sealing system is based on a welded metal bellows, with one end connected to the plug stem and the other to the valve bonnet. This configuration ensures complete isolation of the process fluid from the external environment.

To enhance operational safety, the device is equipped with a secondary back-up seal designed to contain the fluid in the event of failure of the primary bellows. The bellows is supplied as standard in AISI 316L stainless steel. For particularly aggressive fluids or severe operating conditions, it is available on request in special alloys such as Inconel, Monel, or Hastelloy.

A version with a monitoring connection is also available, allowing the installation of pressure switches or other monitoring devices. This solution enables early detection of any internal leakage due to bellows rupture, allowing prompt and targeted maintenance.

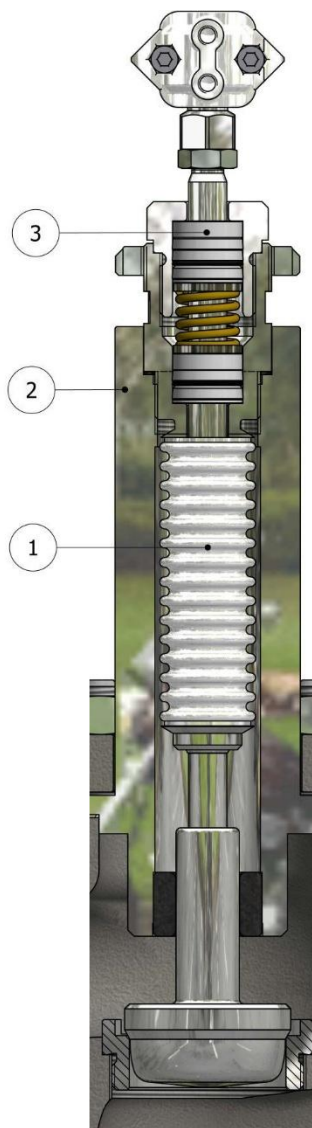

Standard bellows

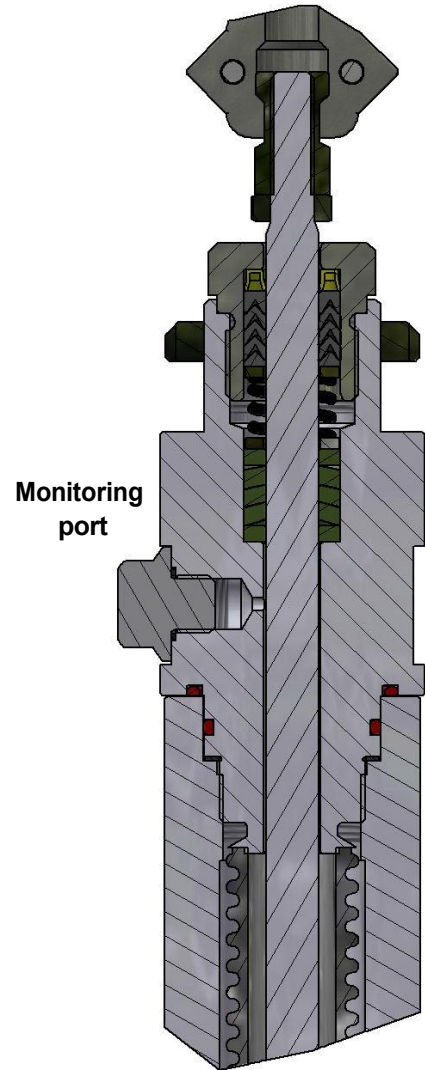

Bellows with monitoring port



Fugitive emissions

ISO 15848-1

ZEB20 - MATERIALS COMBINATION

POS.	DESCRIPTION	STADARD MATERIALS	ON REQUEST
1	Bellow	AISI 316L	Inconel, Monel, Hastelloy or other materials
2	Bonnet	Equal or equivalent to the material of the body valve	Other materials
3	Packing	See packaging chapter	

CONTROL CHARACTERISTICS

QUICK OPENING

A valve with quick opening flow characteristic provides a maximum change in flow rate at low travels and small changes when the valve plug is near maximum. Control valves with quick opening flow characteristics are often used for on/off applications where significant flow rate must be established quickly as the valve begins to open. Consequently they are often used in relief valve applications. Quick opening valves can also be selected for many of the same applications for which linear flow characteristics are recommended.

LINEAR

A valve with linear characteristic provide a flow rate directly proportional to travel. Linear characteristics are commonly specified for liquid-level and flow-control applications.



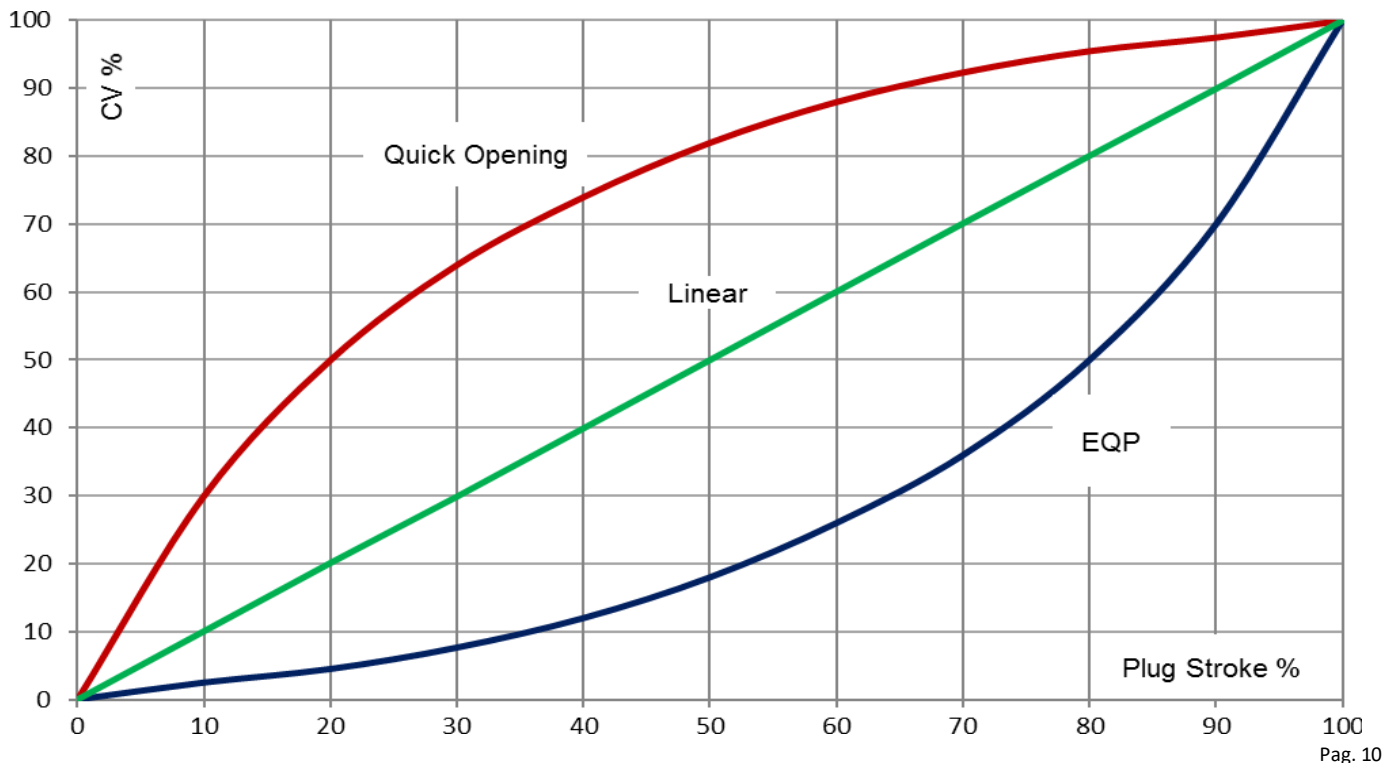

EQUAL PERCENTAGE

In equal percentage flow characteristic, equal increments of valve travel produce equal percentage changes in the existing flow. A valve with an inherent equal percentage flow characteristic provides precise throttling control through the lower portion of the travel range and rapidly increasing capacity as the valve plug nears the wide open position. Valves with equal percentage flow characteristics are used on pressure control applications, on applications where a large percentage of the pressure drop is normally absorbed by the system itself with only a relatively small percentage available at the control valve, and on applications where highly varying pressure drop conditions can be expected.

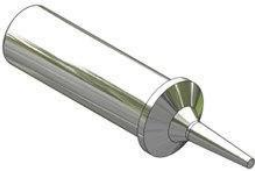

TRIMS CHARACTERISTICS

	STANDARD	ON REQUEST
CONTROL CHARACTERISTICS	Equal Percentage (EQP)	Quick opening (ON-OFF)
		Linear (PL)
PORT	Full port	Reduced port
		Microflow port
SEAL	Metal seat tightness Class IV	Class IV - Stellite faced
		Class IV - Saline nitriding (QPQ)
		Class V - Lapped Only with Quick-Change seat
		Class V - Stellite faced Lapped Only with Quick-Change seat
		Class VI - PTFE soft seal <150°C
		Class VI - PTFE-GR soft seal <200°C
		Class VI - PEEK soft seal <280°C

LINEAR SPLINE PLUG	QUICK OPENING PLUG	EQP PLUG METAL TIGHTNESS	EQP PLUG SOFT TIGHTNESS	BALANCED PLUG
				

BALANCED PLUG CONSTRUCTION

In applications where there is a high flow rate and a high pressure drop valve actuators can struggle to provide tight shut off against the force of the upstream pressure on the plug. In these applications the balanced plug option redirects some of the upstream pressure to balance the influence of the pressure drop across the plug.

This results in a more efficient actuator thrust for a particular size of actuator. This ensures the tightness class of the valve.

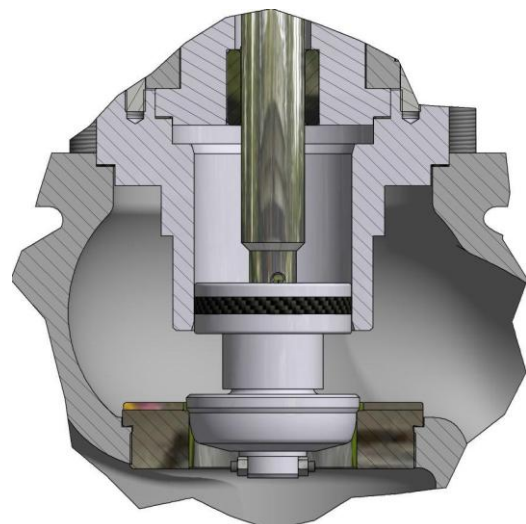

BALANCED TRIM

CAVITATION, FLASHING EFFECT NOISE LEVEL

The globe valve allows the regulation of a parameter which can be the pressure or flow going to modify the flow of pressurized fluid in the system. The principle used is that of the Bernoulli law or the continuity of the fluids. In a globe valve, if I decrease the passage section, the speed increases while the pressure decreases. If this pressure falls below the vapor pressure of the bubbles could be created that could produce two flow disturbance phenomena: cavitation effect and flashing effect:

- Cavitation
- Flashing

Cavitation consists of rapid vaporization and condensation within a liquid. When local pressure falls to vapor pressure (approximately 0.25 psi / 0.018 bar absolute for cold water), vapor bubbles are formed and when these bubbles travel to an area of higher pressure, the bubbles collapse with phenomenal force and great localized stress. It is the violent collapse of these vapor bubbles near valve components or downstream piping surfaces, which cause cavitation damage and subsequent performance degradation. Typically, the reason for low pressure is that the pressure drop across a control valve has created very high velocity in the seat area and corresponding low pressure because potential (pressure) energy is reduced to compensate for the increase in kinetic energy. The principle can be applied to various types of fluid flow and simply states that when there is an increase in the velocity of fluids then it must be accompanied by a decrease in the fluid's pressure, the total energy associated with the flow must remain constant.

The **Flashing** effect is similar to cavitation, except that bubbles explode downstream of the valve.

In control valves, the pressure drop typically occurs at or near the seat area or just downstream. The shock waves and pressure fluctuations resulting from these high velocity bubble collapses can also cause noise, vibrations, accelerated corrosion, as well as limited valve flow. Typically the cavitation is formed in the valve throttling area, the pressure fluctuations radiate into the downstream pipe as noise



ANTICAVITATION CAGE



LOW dB TRIM SINGLE STAGE



LOW dB TRIM DOUBLE STAGE

— not available

■ standard

□ on request

LINEAR & QUICK OPENING PLUG FLOW RATE COEFFICIENTS SEAT BORE DIAMETER AND STROKE

CV	Kv	Seat bore	Plug stroke	Valve size													
		mm	mm	15	20	25	32	40	50	65	80	100	125	150	200	250	300
0.08	0,07	3	20	□	□	□	□	□	□	—	—	—	—	—	—	—	—
0.12	0.10	4		□	□	□	□	□	□	—	—	—	—	—	—	—	—
0.20	0,17	4		□	□	□	□	□	□	—	—	—	—	—	—	—	—
0.35	0.30	4		□	□	□	□	□	□	—	—	—	—	—	—	—	—
0.60	0,51	5		□	□	□	□	□	□	—	—	—	—	—	—	—	—
0.75	0,65	6		□	□	□	□	□	□	—	—	—	—	—	—	—	—
1.00	0,85	7		□	□	□	□	□	□	—	—	—	—	—	—	—	—
1.3	1,11	8		□	□	□	□	□	□	—	—	—	—	—	—	—	—
1.8	1,54	9		□	□	□	□	□	□	—	—	—	—	—	—	—	—
2	1,7	10		□	□	□	□	□	□	—	—	—	—	—	—	—	—
2.5	2,15	10		□	□	□	□	□	□	—	—	—	—	—	—	—	—
3	2,58	10		□	□	□	□	□	□	—	—	—	—	—	—	—	—
3.5	3	10		□	□	□	□	□	□	□	—	—	—	—	—	—	—
6	5.1	20		■	□	□	□	□	□	□	□	—	—	—	—	—	—
8	6,8	20		—	■	□	□	□	□	□	□	—	—	—	—	—	—
13	11	25		—	—	■	□	□	□	□	□	—	—	—	—	—	—
19	16	30	—	—	—	■	□	□	□	□	□	□	—	—	—	—	
29	25	38	—	—	—	—	■	□	□	□	□	□	□	□	□	—	
50	43	49	—	—	—	—	—	■	□	□	□	□	□	□	□	□	
75	64	64	—	—	—	—	—	—	■	□	□	□	□	□	□	□	
112	96	76	—	—	—	—	—	—	—	■	□	□	□	□	□	□	
173	148	100	30	—	—	—	—	—	—	—	—	■	□	□	□	□	
190	162	100	35	—	—	—	—	—	—	—	—	□	□	□	□	□	
280	239	126		—	—	—	—	—	—	—	—	—	■	□	□	□	□
435	372	151	50	—	—	—	—	—	—	—	—	—	■	□	□	□	
720	615	201	60	—	—	—	—	—	—	—	—	—	—	—	■	□	□
990	856	250	75	—	—	—	—	—	—	—	—	—	—	—	—	■	□
1704 (a) (c)	1456 (a) (c)	330	160	—	—	—	—	—	—	—	—	—	—	—	—	—	■

— not available

■ standard

□ on request

(a) not available for quick opening characteristic
 (b) 1.18" (30mm) for quick opening characteristic
 (c) metal-to-metal seal only

DIMENSIONS

DN	A (mm) (*)	B i(mm)	
		PN16	PN40
DN15	130	47.5	
DN20	150	52.5	
DN25	160	57.5	
DN32	180	70	
DN40	200	75	
DN50	230	82.5	
DN65 (*)	290	92.5	
DN80	310	100	
DN100	350	110	117,5
DN125	400	125	135
DN150	480	142.5	150
DN200	600	170	187.5
DN250	730	202.5	225
DN300	850	230	257.5

* According to standard EN1092-1 DN65 valves in steel flanged PN16 must be provided with 8 holes. They can be forseen with 4 holes only on demand.

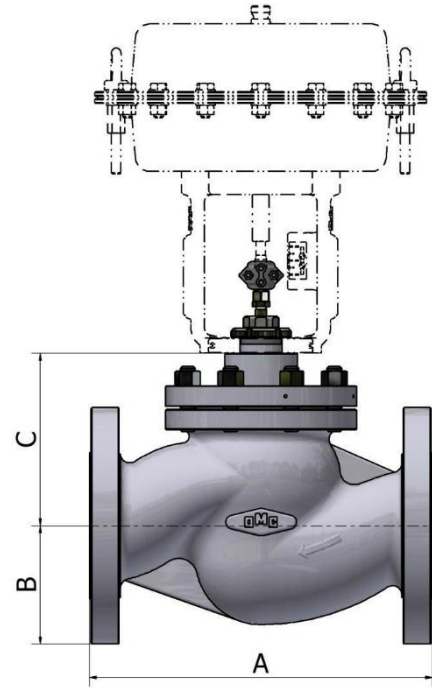

DN	C mm - standard plug									
	BONNET						BONNET WITH BELLOWS			
	(CRYOGENIC) da -196 a 220 °C	(EXTENDED) da -90 a 220 °C	(STANDARD) da -5 a 220 °C	(FINNED) da -5 a 420 °C	(FINNED) da -5 a 520 °C	(FINNED) da -5 a 600 °C	(CRYOGENIC) da -196 a 420 °C	(STANDARD) da -90 a 420 °C	(HIGH TEMP.) da -90 a 520 °C	(HIGH TEMP.) da -90 a 600 °C
DN15	322	163	126	163	244	270	322	226	244	270
DN20	322	163	126	163	244	270	322	226	244	270
DN25	332	173	129	173	254	280	332	228	254	280
DN32	332	173	129	173	254	280	332	228	254	280
DN40	340	185	128	185	263	289	340	226	263	289
DN50	340	185	128	185	263	289	340	226	263	289
DN65	462	255	165	255	360	394	462	292	360	394
DN80	482	260	187	260	372	409	482	306	372	409
DN100	585	310	184	310	449	495	585	307	449	495
DN125	647	369	256	369	510	556	647	369	510	556
DN150	650	372	259	372	513	559	650	372	513	559
DN200	673	395	283	395	536	582	673	395	536	582

DN	C mm - balanced plug									
	BONNET						BONNET WITH BELLOWS			
	(CRYOGENIC) da -196 a 220 °C	(EXTENDED) da -90 a 220 °C	(STANDARD) da -5 a 220 °C	(FINNED) da -5 a 420 °C	(FINNED) da -5 a 520 °C	(FINNED) da -5 a 600 °C	(CRYOGENIC) da -196 a 420 °C	(STANDARD) da -90 a 420 °C	(HIGH TEMP.) da -90 a 520 °C	(HIGH TEMP.) da -90 a 600 °C
DN50	369	214	157	214	292	318	369	256	292	318
DN65	484	277	218	277	382	416	484	334	382	416
DN80	504	282	230	282	394	431	504	348	394	431
DN100	585	310	245	310	449	495	585	365	449	495
DN125	672	394	352	394	535	581	672	472	535	581
DN150	676	398	356	398	539	585	676	476	539	585
DN200	700	422	380	422	563	609	700	500	563	609
DN250	1238	650	453	650	948	1046	1238	650	948	1046
DN300	Tobedefined	Tobedefined	Tobedefined	Tobedefined	Tobedefined	Tobedefined	Tobedefined	Tobedefined	Tobedefined	Tobedefined

NB: For actuator dimensions, refer to the actuator specification.

AVAILABLE END CONNECTIONS



RAISED FACE



RING JOINT FACE



MALE FACE

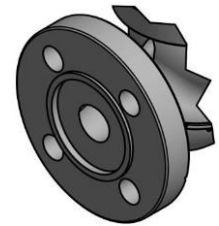

FEMALE FACE



FLAT FACE



BUTT-WELDING



SOCKET-WELDING



GROOVE FACE

VALVE BODY WEIGHT (Kg)

Size	Standard		Extended / Finned		With bellows	
	ANSI 150	ANSI 300	ANSI 150	ANSI 300	ANSI 150	ANSI 300
½"	6	7	7	7	7	8
¾"	6	7	7	8	7	8
1"	7	8	8	9	8	9
1" ½	12	15	13	16	14	17
2"	17	18	18	19	18	20
3"	35	38	38	41	39	42
4"	48	55	53	60	52	59
6"	128	143	137	151	135	150
8"	189	211	197	219	195	218
10"	310	383	381	453	371	443
12"	On request	On request	On request	On request	On request	On request

The valves are suitable for use with the following actuators:

- **Pneumatic:** AX—OP Series
- **Electric:** PS Series
- **Manual:** VM Series